

Discover the Discone

Is this the perfect aerial? Consider simple wire construction, easy one-time tuning, and flat swr from 3.5 to 28 MHz.

With the addition of the new WARC bands, amateur radio operators will have HF allocations at eight points over an eight-to-one frequency range. Multiband antennas will become quite complicated, except for

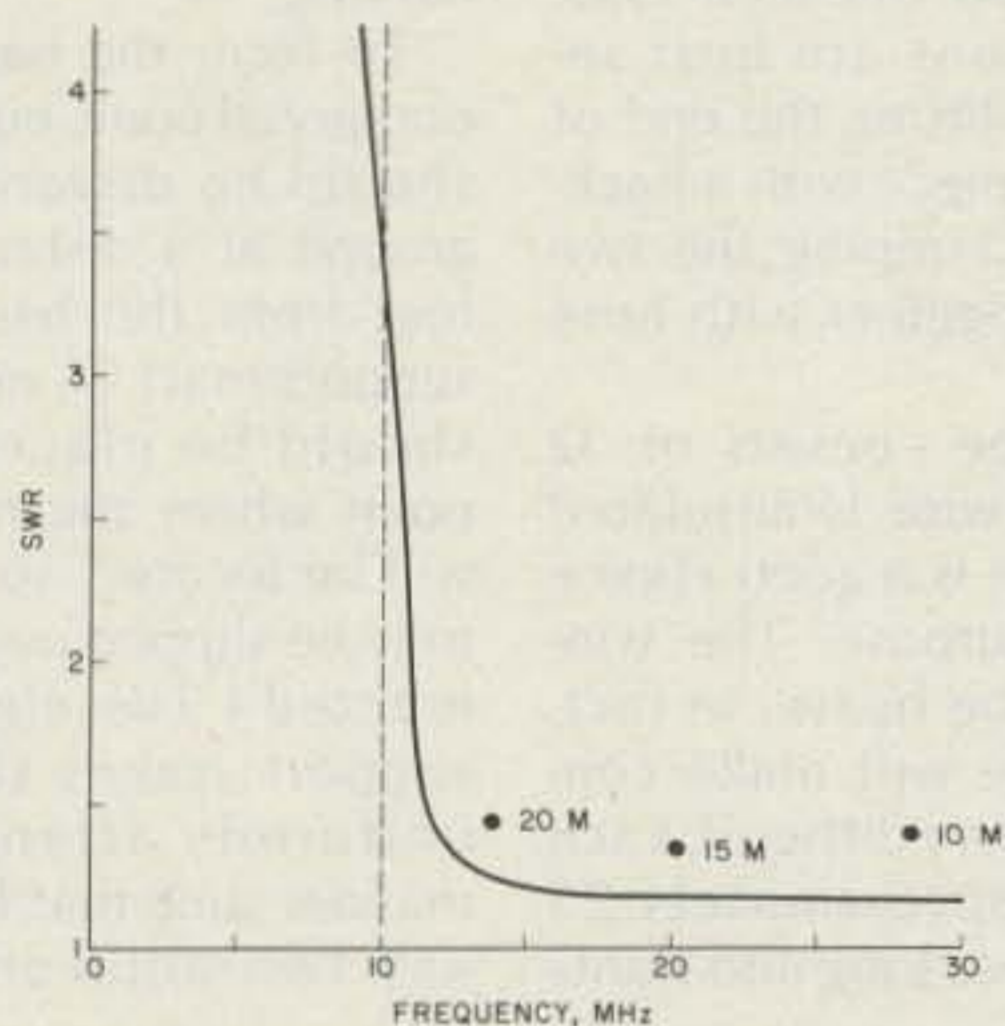

Fig. 1. Swr vs. frequency for a discone antenna having a cut-off frequency of 10 MHz (dotted line). The points show the results of a test at W1GV/4 using the antenna described in this article. Any swr less than 3 was considered tolerable.

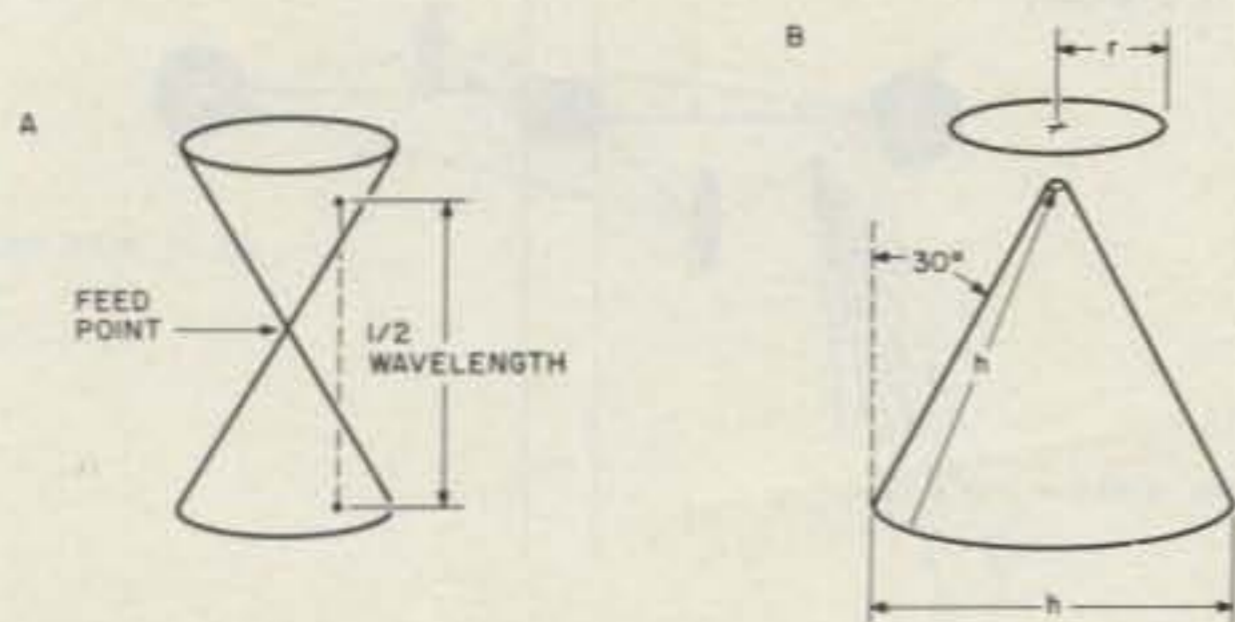

Fig. 2. Design of a bi-conical antenna (A) and a discone (B). The discone is a modified bi-conical antenna, in the same way an inverted ground-plane antenna is a modified vertical dipole.

broadband types, which will probably become more and more popular. Such antennas as the dipole with tuned feeders, the random wire, the log periodic, and others will be used by many hams in pursuit of multiband operation.

This article describes the theory, design, and construction of a broadband vertical for the range 10 through 30 MHz. This antenna is an adaptation of a technique usually seen only at VHF: the discone. This antenna displays vertical polarization and excellent low-angle radiation; it needs no radial system, and it has a fairly flat, low swr curve over a continuous frequency range. A theoretical swr response is illustrated in Fig. 1.

Theory

The concept of the discone originated with the notion that if an antenna could be constructed whose dimensions were specified by angle measures only, then it would function independently of the wavelength. The bi-conical antenna (A in Fig. 2) is one such device. If the two cones extend sufficiently above and below the feedpoint, then resonance can exist at any frequency above f_{min} , where the alti-

tudes of the cones are $1/4$ wavelength. The electromagnetic field flows outward from the feedpoint along the surfaces of the two cones until it reaches points separated by $1/2$ wavelength, as shown. Clearly, this will be possible at any frequency larger than f_{min} , provided the vertices of the cones come together precisely at the feedpoint.

As the frequency is moved below f_{min} , it is no longer possible to find two points on the cone surfaces separated by $1/2$ wavelength in space. Consequently, the swr increases rapidly. When the frequency is lowered so that the slant height, h , of each cone is equal to $1/4$ wavelength, we say that the bi-conical antenna is at f_c —its cutoff point. The swr at cutoff varies depending on the vertex angle of the cones. Below f_c , the swr rises with extreme steepness to prohibitively high values. Thus the bi-conical antenna represents an electrical high-pass filter with a lowest practical frequency of f_c .

A bi-conical antenna obviously presents structural problems at high frequencies although it is perfectly practical at VHF. To reduce the physical size of the antenna, the discone was de-

veloped. Either the top or bottom cone may be replaced with a reflecting radial system, and then the antenna will function over the same frequency range (provided the reflector is large enough). If we replace the lower cone with a radial system and bring the feed-point to ground level, we have an antenna known as a conical monopole. By replacing the top cone with a reflecting disk of sufficient size (B in Fig. 2), we obtain the discone. The discone is to the bi-conical as an inverted ground-plane antenna is to a vertical dipole.

The discone is easier to build than a conical monopole primarily because no ground radial system is necessary. The high-current portion of the antenna is elevated above ground. The disk radius need be only about 1/12 wavelength at the lowest usable frequency, f_c .

Design

The antenna gets its name from the fact that it consists of a disk on top of a cone. The disk radius, r , is 0.08 wavelength at the cutoff frequency, f_c , and the slant height, h , is 0.24 wavelength. These dimensions are free-space values.

Above f_c , the swr drops from about 3.5 to almost a perfect match at f_{min} . In theory, the swr then remains nearly constant for several octaves. Above about the

third harmonic of f_c , the maximum radiation begins to occur at considerable elevations above the horizontal; however, between f_c and $3f_c$ the radiation angle is very low and therefore is excellent for DX work.

At 10 MHz, 0.08 wavelength in free space is 7 feet 10 inches, and 0.24 wavelength is 23 feet 8 inches. The slant height of the cone is equal to the base diameter, making the pitch of the cone 30 degrees from the vertical. This value is not, however, particularly critical. Discones may be built with considerably larger or smaller vertex angles. The value of 30 degrees was chosen since it appears to be the most common value in discone design.

At VHF, discones usually are made from solid metal or screen. For a discone with $f_c = 10$ MHz, this would obviously be ridiculous. However, a wire cage will work very well at longer wavelengths provided the separation between the wires is small. The design scheme for the 10-to-30-MHz discone is shown in Fig. 3. A suggested list of parts is given.

Initial Construction

The center support mast for the HF discone is 23 feet 6 inches high. Aluminum tubing works very well for this purpose and is available in most hardware stores. Three eight-foot sections

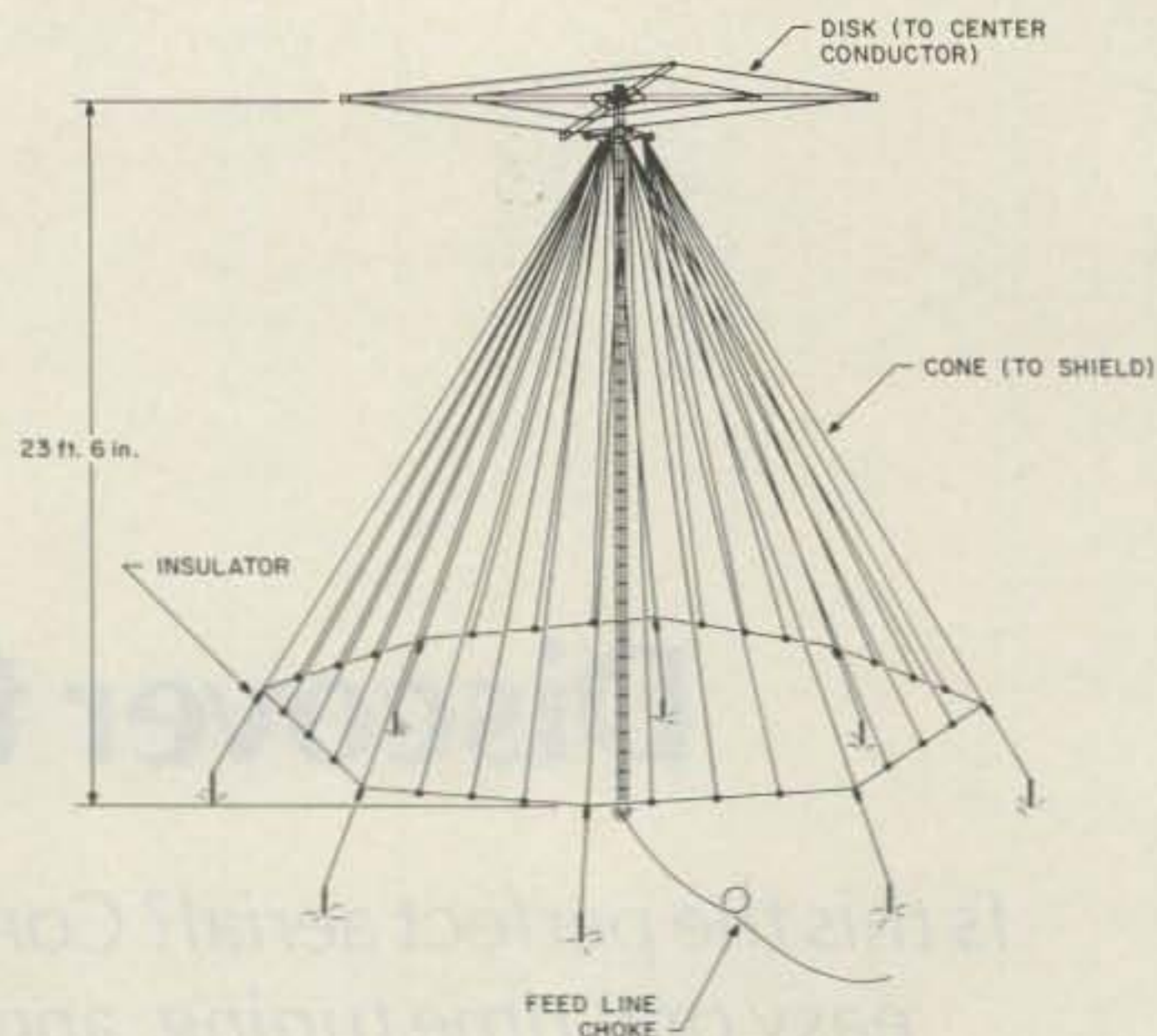

Fig. 3. Construction of the 10-30-MHz discone. The slant height is 23 feet, 8 inches; the square disk has a diagonal radius of 8 feet. The supporting mast is 23 feet, 6 inches high.

may be used, overlapping three inches at the junctions. The top section is one-inch O.D., the center section 7/8-inch O.D., and the bottom section one-inch O.D. The sections are best secured by slitting the end of the larger piece with a hacksaw and clamping the two sections together with hose clamps.

The cone consists of 32 lengths of wire. Uninsulated no. 22 wire is a good choice for this purpose. The wire need not be heavy; in fact, heavy wire will make construction very difficult. Each wire is approximately 23 feet 8 inches long and slants

down at an angle of about 30 degrees with respect to the vertical mast. All the wires are joined at the base of the cone with an octagonal ring.

To form the base of the octagonal cone, eight stakes should be driven into the ground at a distance of 15 feet from the base of the support mast. (A ninth stake should be placed at the point where the mast base will be located, so the mast may be slipped over it when erected.) The eight cone-support stakes should be uniformly arranged in a manner such that lines from any two adjacent stakes

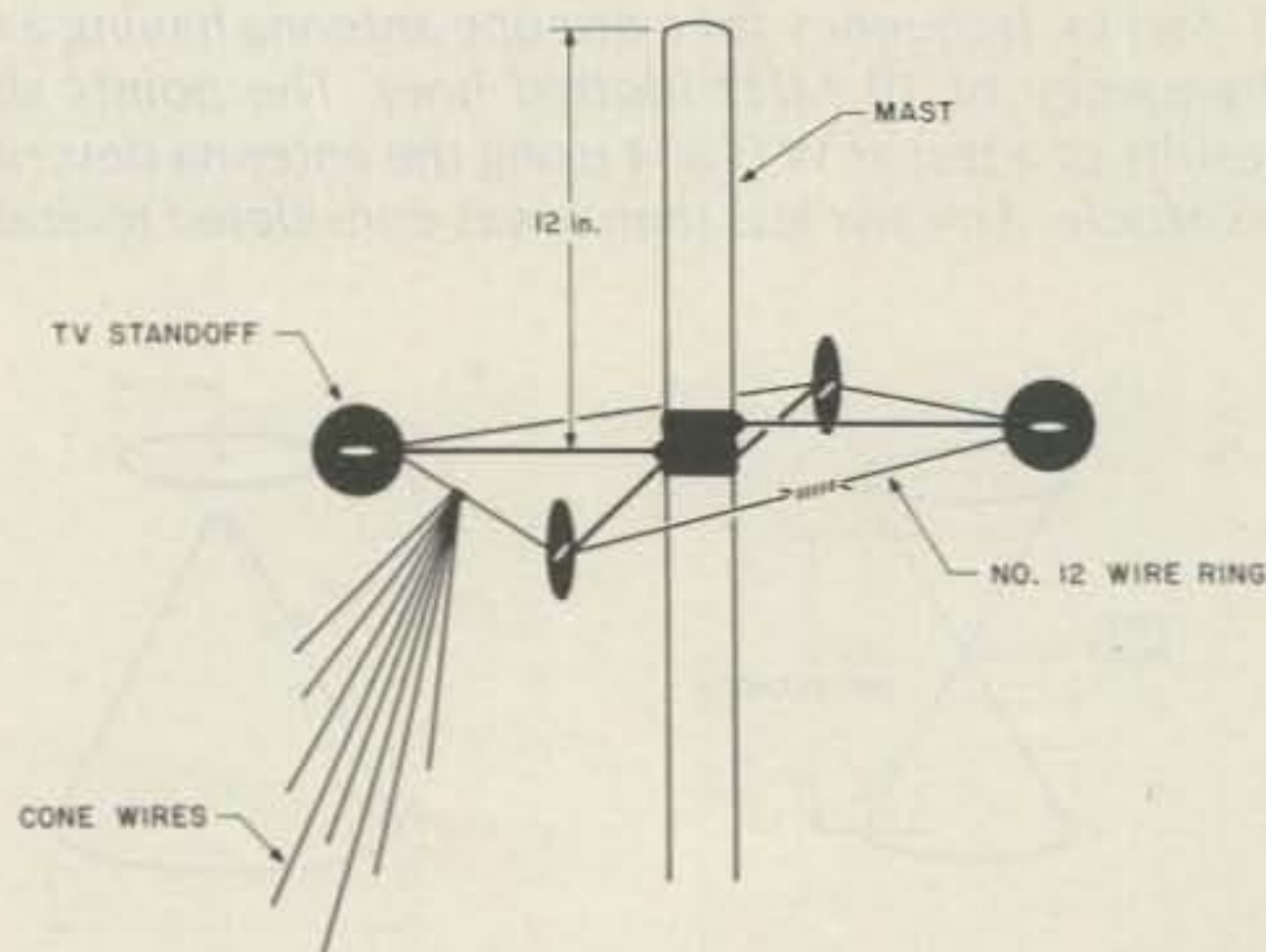

Fig. 4. The ring for the apex of the cone is constructed using no. 12 wire and four clamp-and-screw-type TV standoff insulators. The cone wires are attached in bunches of eight, one bunch to the center of each side of the square.

f_c , MHz	Bands covered, M	r , ft.	h , ft.	Mast*
3.4	80, 40, 30, 20, 17, 15, 12, 10	23.1	69.5	65
6.9	40, 30, 20, 17, 15, 12, 10	11.4	34.2	33
10.0	30, 20, 17, 15, 12, 10	7.9	23.7	23
13.7	20, 17, 15, 12, 10	5.7	17.1	17
17.9	17, 15, 12, 10	4.4	13.2	13
20.5	15, 12, 10	3.8	11.5	11
24.0	12, 10	3.3	9.9	9
27.0	10	2.9	8.7	8

* Minimum heights, in feet.

Table 1. Discone dimensions for various frequencies f_c . (Values of f_c are chosen slightly below the lower end of the nearest amateur band.)

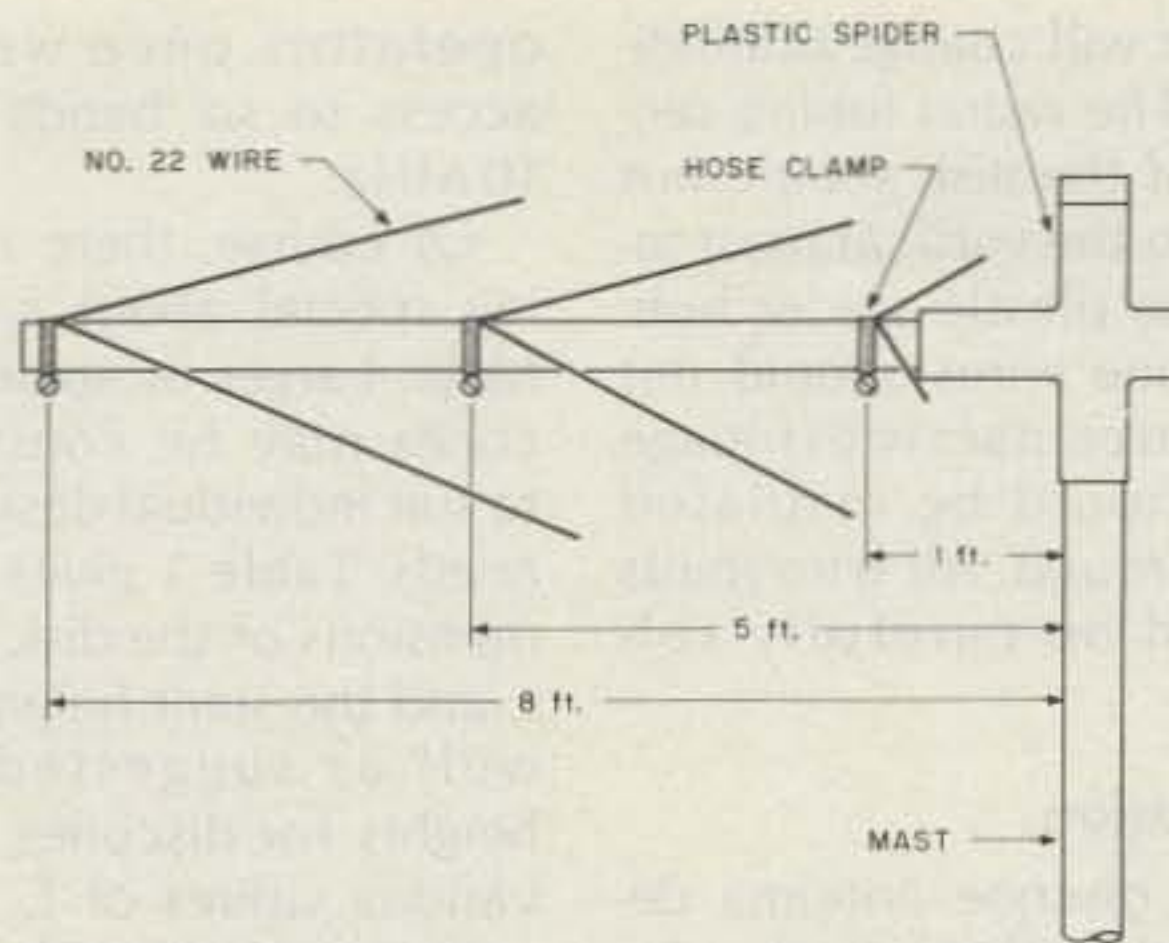

Fig. 5. Radial leg of square disk. Three concentric square rings of no. 22 wire join the radial tubing sections. The disk is mounted at the top of the mast using a plastic quad spider. The mast is wrapped with electrical tape to ensure a tight fit for the spider and also to insulate the disk radials from the mast.

would form a 45-degree angle at the center support point.

The cone apex is constructed as shown in Fig. 4. Four clamp-and-screw-type Radio Shack TV standoff insulators are mounted about one foot below the top of the mast. A length of no. 12 uninsulated solid copper wire should be run through the standoff holes and soldered at the ends to form a square. Caution must be exercised to make sure the ring does not short to the metal parts of the standoffs (and thus to the vertical mast).

To complete the cone, cut 32 lengths of no. 22 wire, each 24 feet long. Solder them in bunches of eight to the center of each side of the apex square. This prevents them from becoming

hopelessly snarled when the mast is put up. Have someone hold the top section of the mast upright at its eventual location and fan the cone wires out along the ground in a uniform radial arrangement.

The "disk" is made from four eight-foot sections of one-inch O.D. aluminum tubing, a quad spider, twelve hose clamps, and more no. 22 wire. Insert the four sections of tubing into the spreader holes of the quad spider so that they form an X. In Fig. 5 we see how the wires are attached to the four radial sections of tubing to form the square disk. The wires should be pinched into a small U shape at each point where they are clamped to the tubing. Three concentric wire squares will

result. The wires should be straight but not under strain since they will contract in cold weather. Mount the square disk at the top of the support mast, using the spider. Wrap the mast with tape to get a tight fit.

Putting It Up

Attach the center conductor of the coaxial feedline (RG-58/U, RG-8/U, or equivalent) to the center of the disk, using a hose clamp at the innermost exposed metal point of one of the radial tubing sections. Attach the outer conductor to the apex of the cone.

Have someone hold the top section of mast, complete with cone wires and disk attached, at the point where the mast is to be erected. Attach two of the cone wires from each bunch to adjacent radial stacks, using an insulator and four extra feet of wire. Raise the mast to its full height while keeping it vertical (a stepladder is almost a necessity to do this!). Tape the coaxial feedline to the mast as it is raised. Once the mast is fully extended, tighten the eight cone wires so that the mast is vertical and is effectively guyed by the wires—but don't pull them excessively tight.

Construct a ring of wire by connecting the eight cone wires together immediately above the insulators. This octagonal ring will be two or three feet above the ground. Then attach the remaining radial wires to the ring in uniform fashion all around. As with the other wires, do not pull them too taut. Each bunch of eight radial wires should run to two adjacent sides of the octagonal cone ring.

The feedline should be decoupled from the antenna at the point where the cable crosses under the cone ring. Otherwise there may be antenna currents on the feedline, with consequent problems. Wind the cable into a tight coil about five or six

inches in diameter with 10 to 15 turns. This will choke off unwanted currents on the outside of the coaxial cable while leaving its performance as a feedline unaffected.

Testing

Once the discone is complete, you are ready to test it for swr. Results of testing at W1GV/4 are illustrated by the points in Fig. 1 at 14, 21, and 28 MHz. The swr is expected to begin rising at about 12 MHz. In theory, it should be about 3.5 at 10 MHz.

If the swr is a bit higher or lower than the values shown in Fig. 1, it is probably because of the ground conductivity (which can range from rotten to excellent) and also perhaps because of objects such as trees and electrical wires in the near field of the antenna. In some cases, sharp increases in swr may appear mysteriously at certain frequencies well above f_c . These cases are usually attributable to resonances in nearby objects such as other antenna towers and masts. Keep the discone as far away as possible from other antenna structures.

Since the discone is a vertically-polarized antenna and has a broadband response, it may pick up more man-made noise than resonant (narrowband) or horizontal antennas. A transmatch at the station end of the feedline will give the discone some selectivity, which should help reduce this noise if it is a problem. The transmatch also will reduce harmonic radiation. Hopefully, your transmitter has enough harmonic attenuation already, but the discone offers none at all.

If the swr is not reasonably low and flat (2 or less above f_{min}) and there are no known resonant structures nearby, check to be certain there are no open or short circuits in the system. If the cone apex ring should happen to touch the metal part of one of the TV standoffs,

Parts List

Aluminum tubing, 7/8" O.D., 8' long	1
Aluminum tubing, 1" O.D., 8' long	6
Electrical tape, large roll	1
Ground stake, 2' long, minimum	9
Hose clamp, 1-1/4"	15
Insulator, porcelain or glass, 4"	8
Spider hub, plastic*	1
Standoff, TV type, clamp-and-screw	4
Wire, uninsulated no. 22, 1000 ft. roll**	1
Wire, uninsulated no. 12, 5-ft. length	1

*Propagation Products, 1855 Cassat Avenue, Jacksonville FL 32210

**Mouser Electronics, 11433 Woodside Avenue, Lakeside CA 92040

QUALITY PARTS AT DISCOUNT PRICES!

<p>SUB-MINIATURE D TYPE CONNECTOR</p> <p>SOLDER TYPE SUB-MINIATURE CONNECTORS USED FOR COMPUTER HOOK UPS.</p> <p>DB-15 PLUG \$2.75 DB-15 SOCKET \$4.00 DB-15 HOOD \$1.50 DB-25 PLUG \$2.75 DB-25 SOCKET \$3.50 DB-25 HOOD \$1.25</p> <p>"PARALLEL" PRINTER CONNECTOR</p> <p>SOLDER STYLE 36 PIN MALE USED ON "PARALLEL" DATA CABLES.</p> <p>\$5.50 EACH</p>	<p>L.E.D.'S STANDARD JUMBO DIFFUSED</p> <p>RED 10 FOR \$1.50 GREEN 10 FOR \$2.00 YELLOW 10 FOR \$2.00</p> <p>FLASHER LED 5 VOLT OPERATION RED JUMBO SIZE \$1.00 EACH</p> <p>BI POLAR LED 2 FOR \$1.70</p>	<p>2 AMP SOLID STATE RELAY</p> <p>SIZE: 1 1/2" x 1-7/8" x 1/4" HIGH</p> <p>CONTROL: 3.6-6 VDC TTL compatible. LOAD: 120 Vac @ 2 amp</p> <p>\$2.50 each 10 for \$23.00</p>
<p>CRYSTAL CASE STYLE HC33/U COLORBURST 3579.545 KC 2 MHZ \$3.50 EA \$1.00 EACH</p>	<p>13 VDC RELAY</p> <p>CONTACT: S.P.N.C. 10 AMP @ 120 VAC ENERGIZE COIL TO OPEN CONTACT. COIL: 13 VDC 650 OHMS SPECIAL \$1.00 EACH</p>	

SEND FOR **NEW 1985 48 PAGE CATALOG FREE!**

<p>MINIATURE TOGGLE SWITCHES</p> <p>ALL ARE RATED 5 AMPS @ 125 VAC</p> <p>S.P.D.T. (on-on)</p> <p>P.C. STYLE, NON-THREADED BUSHING 75¢ EACH 10 FOR \$7.00</p> <p>S.P.D.T. (on-on)</p> <p>SOLDER LUG TERMINALS \$1.00 EACH 10 FOR \$9.00 100 FOR \$80.00</p>	<p>SOLID STATE BUZZER</p> <p>STAR #SMB-06L 6 VDC. TTL COMPATIBLE.</p> <p>\$1.00 EACH 10 FOR \$9.00</p>	<p>EDGE CONNECTORS</p> <p>22/44 22/44 GOLD PLATED CONTACTS 156 CONTACT SPACING.</p> <p>\$2.00 EACH 10 FOR \$18.00</p>
<p>S.P.D.T. (on-off-on)</p> <p>NON-THREADED BUSHING. P.C. STYLE 75¢ EACH 10 FOR \$7.00</p> <p>S.P.D.T. (on-on)</p> <p>P.C. LUGS, THREADED BUSHING. \$1.00 EACH 10 FOR \$9.00 100 FOR \$80.00</p>	<p>120V INDICATOR</p> <p>NEON INDICATOR RATED 120 V 1/3 W MOUNTS IN 5/16" HOLE</p> <p>75¢ EACH RED LENS 10 FOR \$7.00 100 FOR \$65.00</p>	<p>SWITCHING POWER SUPPLY</p> <p>INPUT: 14 Vac-25.5 Vac OUTPUT: +12 Vdc @ 350 ma +5 Vdc @ 1.2 amp -5 Vdc @ 200 ma SIZE: 4 3/4" x 4 3/4" x 1 1/4" high</p> <p>\$5.00 each</p>

ALL ELECTRONICS CORP.
905 S. VERMONT • P.O. BOX 20406 • LOS ANGELES, CA 90006
TOLL FREE ORDERS • 1-800-826-5432
(IN CALIFORNIA: 1-800-258-6666)
AK, HI, OR INFORMATION • (213) 380-8000

• QUANTITIES LIMITED • FOREIGN ORDERS INCLUDE SUFFICIENT SHIPPING
• MINIMUM ORDER \$10.00 • CALIF. RES. ADD 6.12%
• USA \$3.00 SHIPPING NO C.O.D.

the swr will change dramatically. The radial tubing sections of the disk should not short to the vertical mast inside the plastic spider hub. The cone wires should not come in contact with foliage and should be insulated from ground. All wire joints should be carefully soldered.

Conclusion

The discone antenna described in this article was built and tested at W1GV/4 in the summer of 1981, at which time I had the good fortune to be able to use nearly an acre of real estate. Results were as expected. The antenna performed very well for DX on 20, 15, and 10 meters. This is undoubtedly because of the low angle of radiation and the fact that the feedpoint is well elevated above the level of most nearby obstructions, especially houses (which are almost all single-level structures in Florida!). The discone should be a great convenience for multiband

operators once we have access to six bands above 10 MHz.

Of course, there is nothing special about $f_c = 10$ MHz. Larger or smaller discones may be constructed to suit individual desires and needs. Table 1 gives the dimensions of the disk radius, r , and the slant height, h , as well as suggested mast heights for discones having various values of f_c . A discone for 80 through 10 meters is not out of the question if you have a 65-foot tower and a strong pair of legs! The disk, while quite large, could be supported with nylon rope trusses. A lot of wire would be needed for the cones! For serious low-band DXers, though, such a system could be more than worth the effort. ■

References

- Bill Orr, *Radio Handbook* (nineteenth edition), Howard W. Sams & Co., Inc., 1972.
- Reference Data for Radio Engineers* (sixth edition), Howard W. Sams & Co., Inc., 1975.

- See a change in your Challenger
- Put some fun in your Flescher
- Get your CP-1 in the chips
- Really motivate your MFJ
- Heat-up your HAL and hop-up your Heath with the...

AIRDISK

AND AIR-ROM CARTRIDGE
For both the COMMODORE 64 and VIC 20
(Soon for the new C-128)

Works with all these fine terminal units to bring you the ultimate in RTTY/CW/AMTOR performance. New AMTOR+ program with variable PTT delay for slower rigs and high rate bit sync to compensate for computer clock crystal variations. It's the best \$39.95 you'll



ever spend to improve your station. Don't have a disk drive, then use the ROM cartridge at \$59.95. On performance and features vs. cost, nothing even comes close! No complicated menus to bog you down. No limited performance programs here. The AIRDISK will enhance any demodulator. Disk works with both computers. Specify which for cartridge.



HERE ARE A FEW OF ITS MANY FEATURES:

- on screen tuning indicators • full or split-screen
 - auto-load memories* • output to commodore printers • full speed operation, morse to 99 wpm. Baudot to 132 wpm, ASCII to 300 Baud • 4 mode AMTOR • WRU • independent RX/TX normal/invert
 - pitch reference CW tuning • real-time disk communication* • break buffer • random code generator • RX/TX of basic programs* • 24 hr. clock • unshift or space • foxtest and more.
- 18713 Mooney Drive Gaithersburg, Md. 20879
301 258-8400
*Disk only

MICROLOG

INNOVATORS IN DIGITAL COMMUNICATION